

Access control switch power supply

AC 110V~220V input
DC 12V, 5A output



SMQT

• Parameter

SMQT

Paramètre	
Produit prénom	Concis Contrôle d'accès Alimentation pour le système de contrôle d'accès
Modèle	EA-32A
Dimension	120 × 96 × 38 (mm)
Contribution Tension	AC110V-220V
Contribution la fréquence	50-60Hz
Sortie Tension	12V DC
output Courant	5A
protection	Encastré sortie court-circuits, ou les protections et de surcharge
Couleur	gris, vert
Convient pour	Accès contrôle sysetm
Environnement temprature	-20 °C ~ 61 °C
Poids net	0,32 kg

• Introduction

SMQT

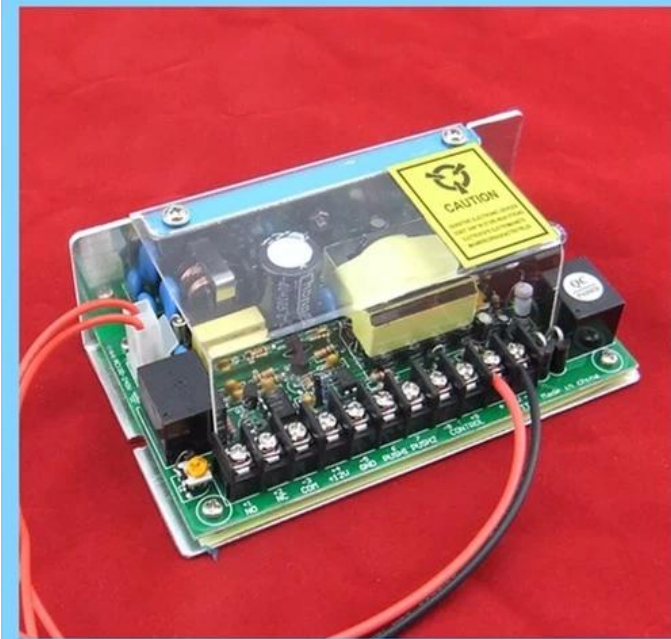



Concise access control switch power supply

AC110V~240V input voltage

50~60Hz input frequency

DC 12V,5A output

Double side PC board,pure copper transformer

2 years quality warranty, welcoem OEM

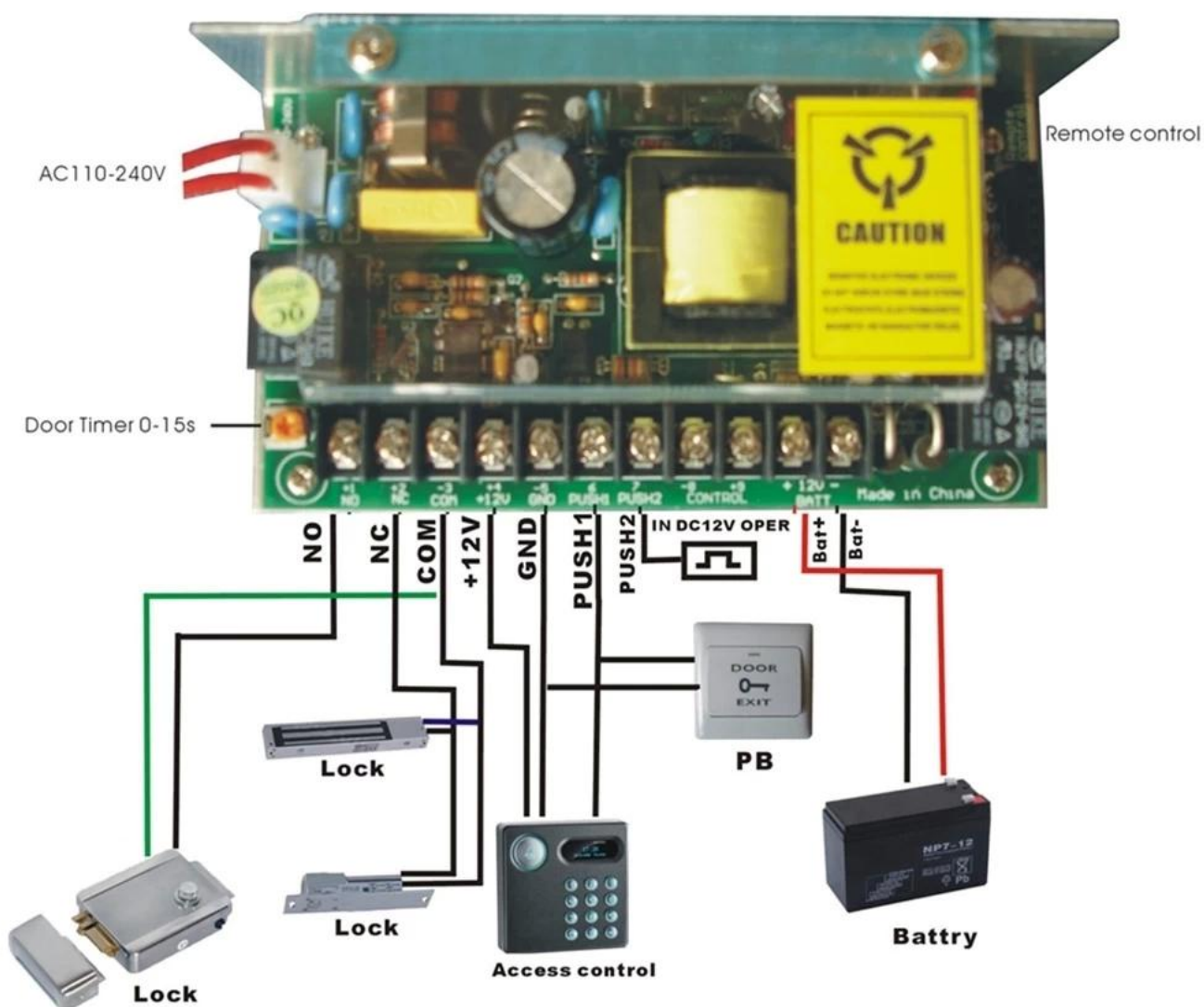

Liste d'emballage

Nom du produit	EA-32A Concise Puissance Contrôle d'accès d'alimentation pour le système de contrôle d'accès
Quantité	41 pcs par carton
taille de carton	45 * 32 * 32 (cm)
Poids	15 kg



WE LOGISTICS



• Office show

SMQT



• Exhibition

SMQT

2011 Brazil Fair



2012 Shenyang Fair



2013 Jinan Fair



2013 Shenzhen Fair



.....



2012 Shenyang Fair



2013 Shenyang Fair



2013 Shenzhen Fair



2015 Shenzhen Fair