

Sensor de contacto magnético de puerta de obturador a prueba de agua con soporte



PARÁMETRO PRINCIPAL DEL EB-137B

Nombre del producto:	Sensor de contacto magnético de puerta de obturador a prueba de agua con soporte
Número de modelo:	EB-137B
Tensión de trabajo:	Max DC 100
Corriente de trabajo:	Max 0.5A
El consumo de energía:	10W
Puerto de interfaz:	NC / COM
Brecha de inducción:	20 ~ 30 mm
Tamaño:	Reed parte: 106 * 38 * 10 (mm) Parte magnética: 106* 16 * 16 (mm) Parte del soporte: 106 * 48 * 48 (mm)
Característica:	Uso de la puerta del obturador, con soporte
Adecuado para:	Todo tipo de sistema de control de acceso a la puerta y sistema de alarma antirrobo
Material:	Carcasa ABS + placa PCB + interruptor Reed
Color de la vivienda:	Plata

Peso:	1 par por bolsa, por bolsa de peso 280g
Garantía:	2 años de garantía
OEM:	Bienvenido OEM

LA FERIA DE EB-137B

Waterproof



Size

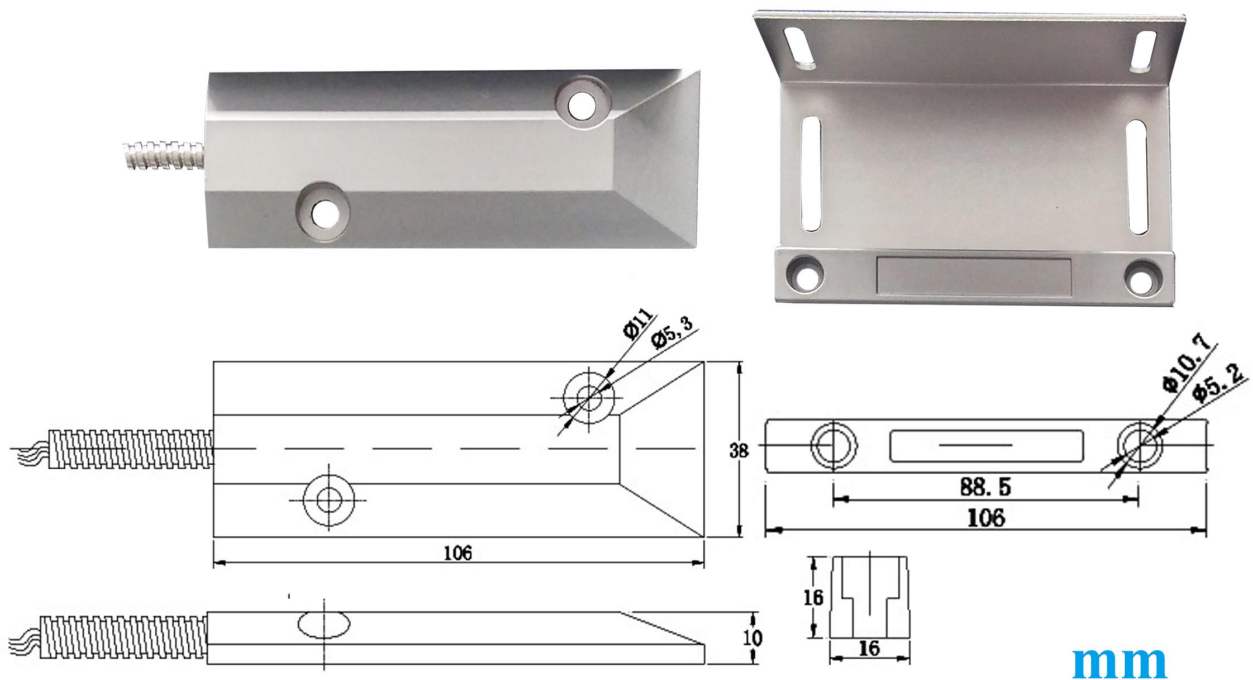

mm

NC mode working principle

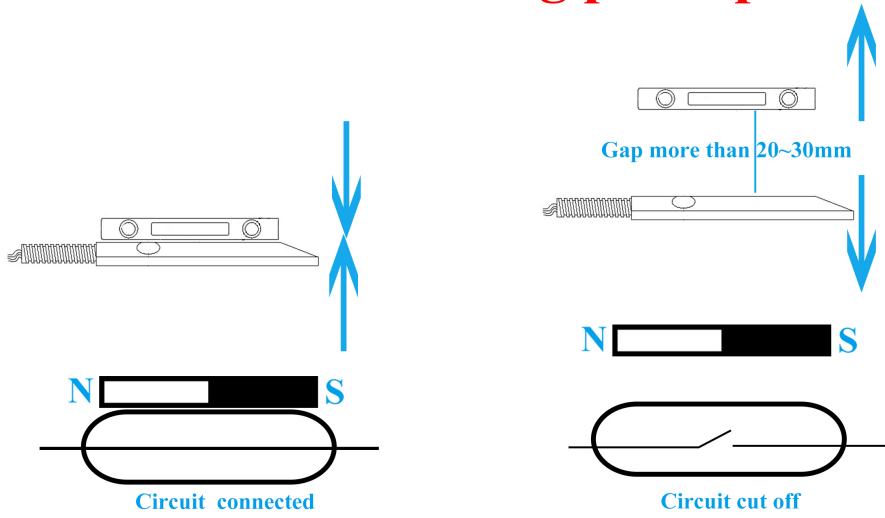

Installation

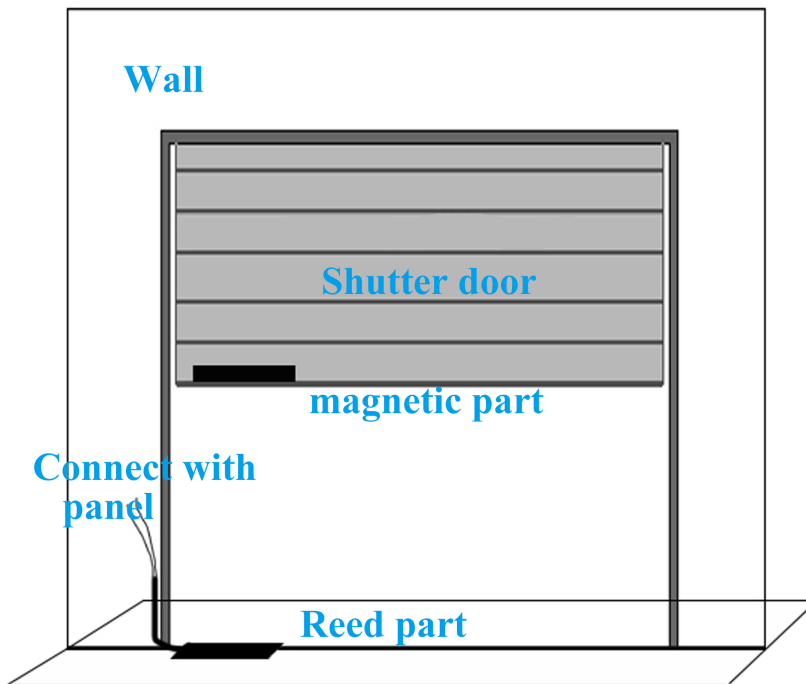

Packaging



1pairs per bag

¿CÓMO SOBRE OTRA OPCIÓN?

SMQT[®]
铭汗科技



SMQT[®]
铭汗科技

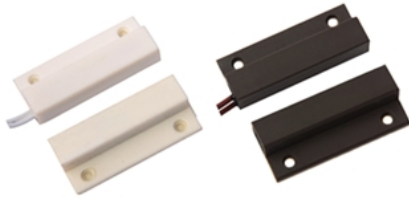

SMQT[®]
铭汗科技

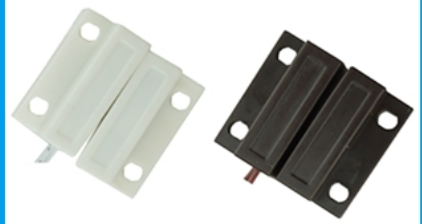

SMQT[®]
铭汗科技



SMQT[®]
铭汗科技



SMQT[®]
铭汗科技

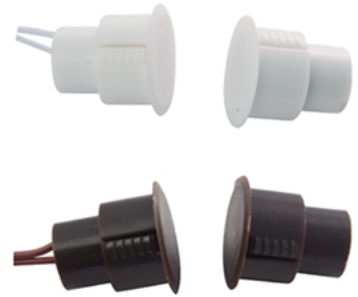

SMQT[®]
铭汗科技



SMQT[®]
铭汗科技



SMQT[®]
铭汗科技

