

Wired infrared 2 beams perimeter detector



no intruding
no across

• Parameter

SMQT®

Nome del prodotto	Outdoor sensore del fascio impermeabile
Numero di modello	ABT
tensione di esercizio	13.8 ~ 24VDC 11 ~ 28VAC
Corrente di funzionamento	40-65mA
velocità indicazione	50 ~ 700 m / sec
uscita anti-demolizione	NC
temperatura ambiente	-20 °C ~ + 50 °C
uscita di allarme	NO / NC
regolazione del livello	180 ° ± 90 °
regolazione Vertical	± 10 °
Colore	Nero
Materiale	resina PC

• Introduction

SMQT®

PRODUCT PICTURE



Il rilevatore di movimento barriera a raggi infrarossi viene utilizzato sul recinto

come il lavoro a infrarossi rilevatore di recinzione con il sistema di allarme.

• Dimension

SMQT®

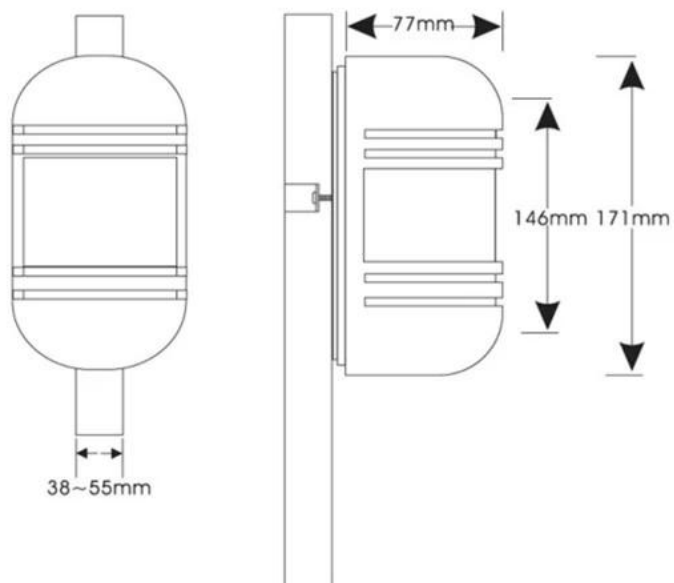

• Feature

SMQT®

PRODUCT FEATURE



Sealed integration structure is able to work in the harsh environment

Automatically regulate to confront with fog or inclement weather

Sensitivity (AGC circuit)

easily adjust and calibrate the horizontal/vertical optional angle

Built-in integrate optical telescopes, anti-jamming jacket

Anti-lighting circuit designed

High-power infrared receiver on the tubes, low-power digital

● *Packaging & shipping*

SMQT®



● *Office show*

SMQT®



● *Exhibition*

SMQT®

2011 Brazil Fair



2012 Shenyang Fair



2013 Jinan Fair



2013 Shenzhen Fair



.....



2012 Shenyang Fair



2013 Shenyang Fair



2013 Shenzhen Fair



2015 Shenzhen Fair