

Vibrate sensor and indoor safety PIR Sensor EB-189

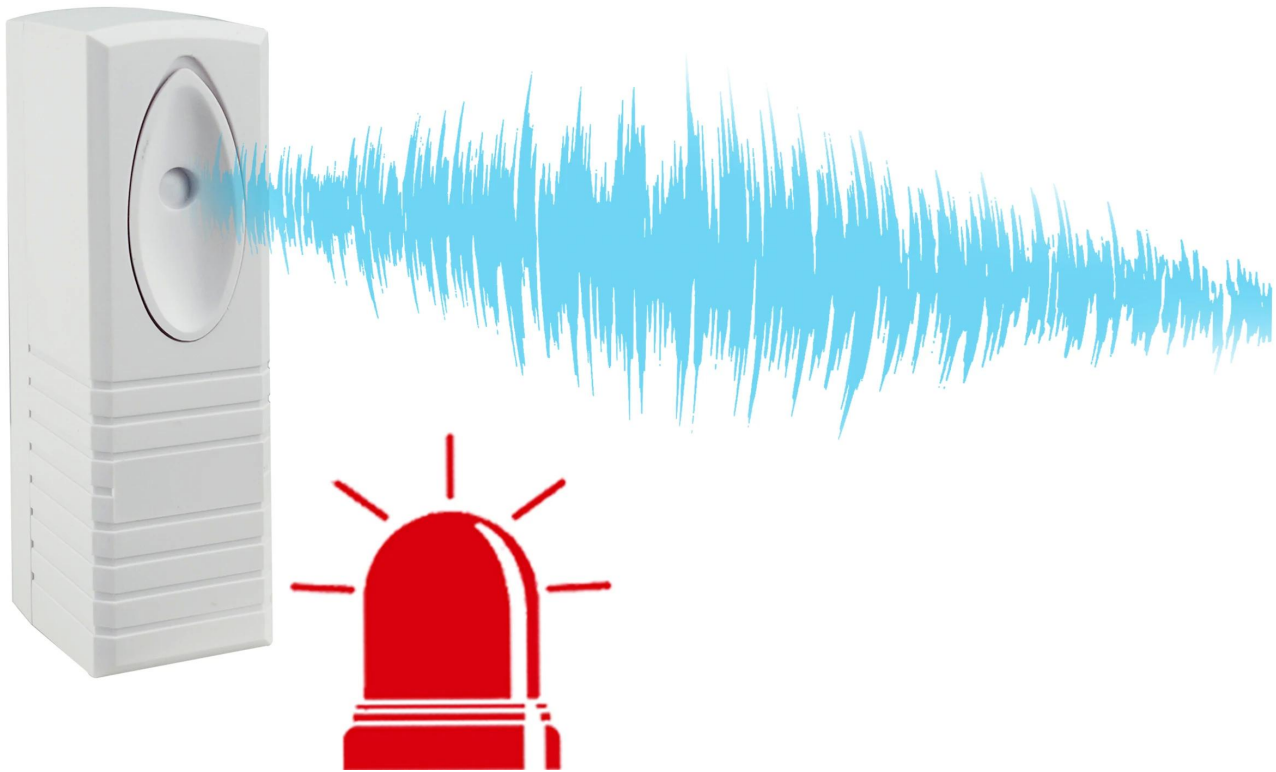

EB-189's main parameter

Specification	
Product name	Wired acoustic vibration detector for violent destruction alarm
Model	EB-189
Size	85*26*25mm
Working voltage	9~16V DC
Current	11mA(Under 12V DC power supply)
Alarm contact	0.1A,24V, NC
Tamper contact	0.1A,24V,NC
Installation way	surface-mounted
Alarm time	2.2s min
Working temperature	-10°C~50°C
Storage temperature	-25°C~65°C
Color	White
Weight	0.1kg

Features

EB-189 digital vibratory detector use the international advanced photoelectric sensor elements with CPU processing technology to ensure the rigorous monitoring for the protective coverage. adjustable detective sensitivity in order to balance point correctly. It is applicable to automatic teller machine(ATM) and

wall and Glass and strongbox etc. and prevent any action of knock and destruction.

What features does EB-189 have?

Size



:mm

PCB board display



Sensitivity Adjustment

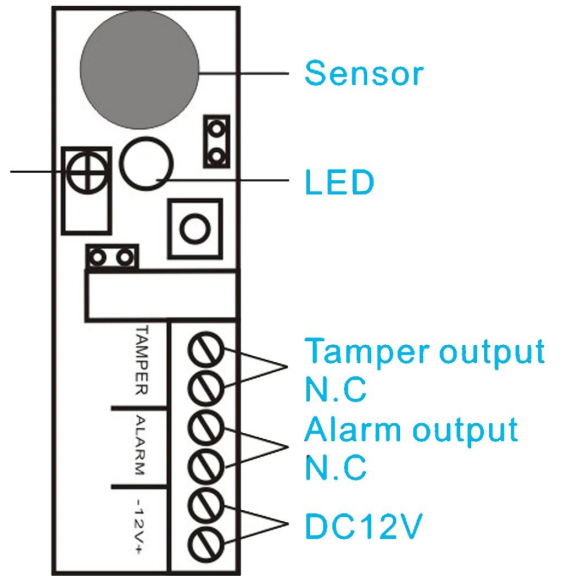

Where to use?

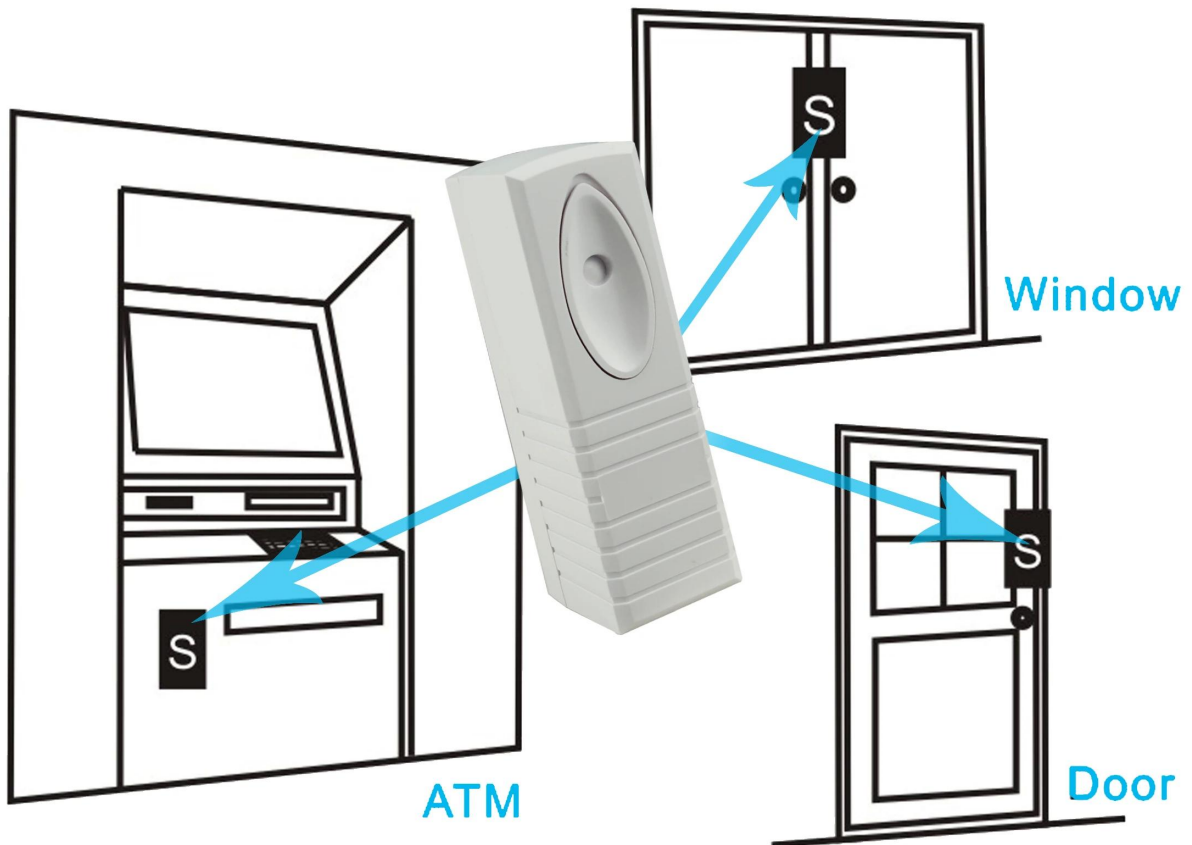

Note: detecting distance is different according different installation enviroment:concrete 1.5m , brick wall 2.5m, iron and steel 3m, glass 3.5m, wood 3.5m

Package



Weight:50g

How about other Choice?



